

OTTO ENVIRONMENTAL SYSTEMS

Waste Systems



2-wheel
mgb 60-340



2-WHEEL WASTE CONTAINERS

mgb 60/80/120/140/180/240/340



ANY VOLUME TO MATCH YOUR NEEDS

OTTO can offer you a full range of 2-wheeled bins, ergonomic and robust in design, certified according to EN 840 and ready to be customised with optional extras. Our 2-wheeled bin will do his job day after day, ensuring a problem free collection and keeping your operational costs under control.

Comb-type frontal receiver

- Deeper combs ensure optimum accommodation by the lifting device and facilitate the use of side loaders
- Additional honeycomb/diamond texture for high safety and a long service life
- Eight webs in the chip nest ensure reliable chip positioning



Lid with bow-type handle



Lid with lip handle



Handle bar, diameter 30 mm



Deeper combs ensure optimum accommodation on the lifting device

Material HD polyethylene

- Environment-friendly
- Long service life
- Suitable for recycling
- Frost-resistant
- Resistant to chemicals
- High resistance to UV radiation

Standard colours

- Grey, green, brown, blue
- Other colours on request
- Colour additions without heavy metals

- Comb design according to DIN or AFNOR, DU receiver (Diamond) as an optional extra

Handle bar

- Optimised ergonomic design by larger tube diameter

Optional extra: third handle

- Handle position in the lower front area facilitates container handling in basements

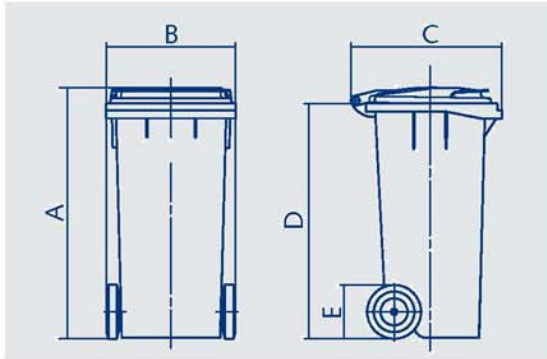

Optional extra: individual marking

- White OTTO logo on the body
- Hot stamping
- Serigraphy on the body and the lid
- Marking by laser
- Injection moulding of texts, coats of arms, etc.
- Inmould labeling on request

OPTIONAL EXTRAS

- Identification systems
- Locking devices
- Various recycling apertures
- Mechanical lid opening
- Noise reduction set
- Solutions for organic waste
- Holder for refuse bag
- Container with ADR approval
- Various designs for container immobilisation
- Inmould labeling

MGB	60	80	120	140	180	240	340
Nom. volume (l)	60	80	120	140	180	240	340
Dead weight approx. (kg)	10	10	11,3	12	14,2	15,5	23
Useful load (kg)	40	40	48	56	72	96	136
A Overall height (mm)	940	940	935	1065	1070	1065	1095
B Overall width (mm)	445	445	480	480	480	580	625
C Overall depth (mm)	520	520	560	560	730	735	860
D Upper edge comb (mm)	872	870	870	1000	1000	990	1000
E Wheel diameter (mm)	200	200	200	200	200	200	200/300

Containers according to EN 840 Subject to technical modification

MGB 240 with integrated wheels
Stackable in completely assembled condition

- Cost-efficient distribution
- Space-saving storage
- Optimised logistics



Wheel/Axle

- Solid rubber tyres and solid steel axel (providing high stability and a long lifetime)
- Corrosion protection by electrogalvanising and chromating

Smooth interior

- Ensures optimum emptying and easy cleaning

2-WHEEL WASTE CONTAINERS

mgb 60/80/120/140/180/240/340

INFORMATION & CONSULTATION

We are at your disposal - providing assistance at all planning stages, from the concept to the installation and maintenance.

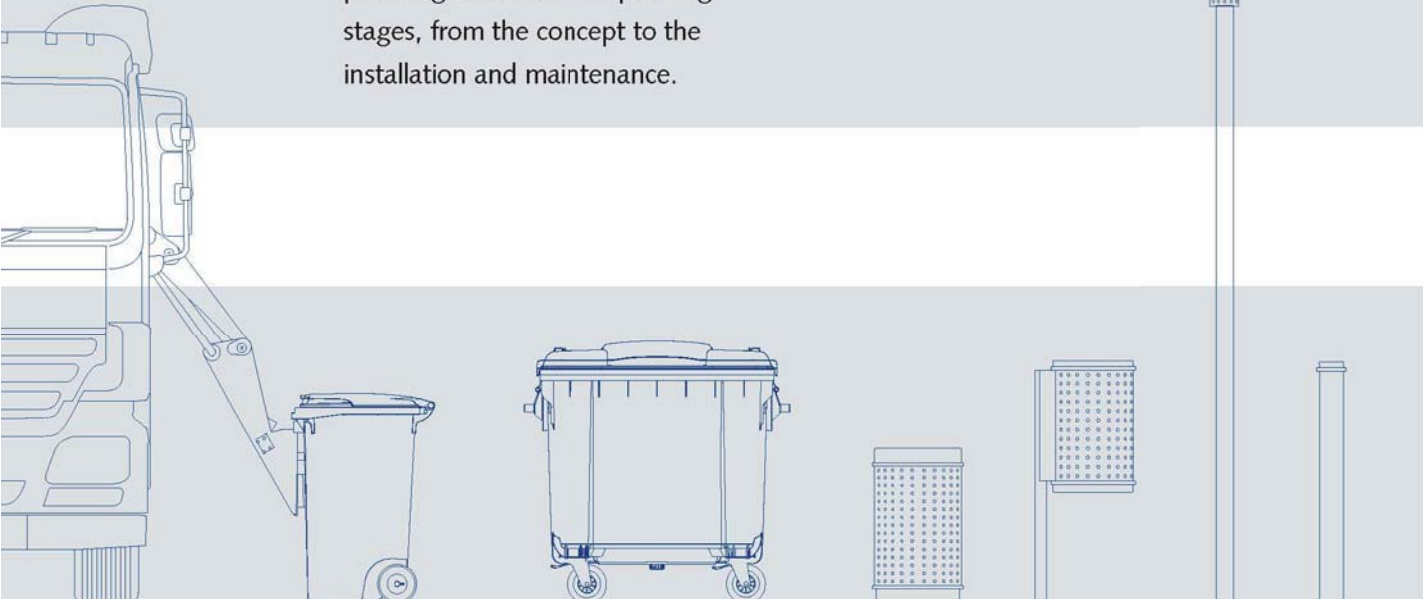

Our product and service range:

OTTO WASTE SYSTEMS

Systems for domestic and industrial waste

OTTO INTERMEDIATE BULK CONTAINERS

Approved special containers

OTTO LIFT SYSTEMS

Collecting vehicles and lifters

OTTO PUBLIC FURNISHING

Litter bin systems and street furniture

OTTO SERVICES

Logistics, financing, data management

Our expertise:

CONSULTANCY

Designing of innovative tailor-made systems

DEVELOPMENT

Designing of optimum receptacles

PRODUCTION

Manufacturing at OTTO owned plants

DISTRIBUTION

Local connection to a global network

SERVICE

Meeting individual needs with custom solutions

CONTRA International
info@contraitl.com ; www.contraitl.com

